

NO	QTY	DESCRIPTION	MODEL NUMBER		STANDARD SEAL KIT	FKM SEAL KIT
			14-2209-01-X-US	14-2213-01-X-US		
1	1	BUTTON HEAD CAP SCREW	21-5000-09	21-5000-10	NO	NO
2	3	BALL, STEEL ALLOY	23-6000-11	23-6000-02	YES	YES
3	1	SENSOR, ULTRASONIC	29-7402-00	29-7402-00	NO	NO
4	4	PLUG, SOCH, SAE 2	30-6011-22	30-6011-22	NO	NO
5	2	PLUG, SOCH, SAE 4	30-6011-44	30-6011-44	NO	NO
6	2	O-RING, MANIFOLD (STANDARD)	39-0000-50	39-0000-50	YES	NO
	2	O-RING, MANIFOLD (FKM)	39-0510-22	39-0510-22	NO	YES
7	1	SEAL, ROD (STANDARD)	39-0100-20	39-0110-46	YES	NO
	1	SEAL, ROD (FKM)	39-V100-20	39-V110-46	NO	YES
8	1	O-RING, RETAINER	39-0510-31	39-V510-43	YES	YES
9	1	WIPER, ROD, (FLUOROCARBON)	39-0530-01	39-0530-00	YES	YES
10	1	PLUNGER, LEFT HAND (SHOWN)	81-4000-84	81-4000-87	NO	NO
	1	PLUNGER, RIGHT HAND	81-4000-85	81-4000-88	NO	NO
	1	PLUNGER, STRAIGHT	81-4000-86	81-4000-89	NO	NO
11	1	RETAINER	81-4000-81	81-4000-82	NO	NO
12	3	BALL SEAT ASSEMBLY	90-1999-57	90-1999-58	YES	YES
13	1	BACK-UP RING, ROD	39-F540-01	39-F540-02	YES	YES
14	1	SEAL, PLUNGER (STANDARD)	39-H100-18	39-H110-30	YES	NO
	1	SEAL, PLUNGER (FKM)	39-V100-18	39-V110-30	NO	YES
15	1	SENSOR, FACE SEAL (STANDARD)	43-0000-40	43-0000-40	NO	NO
	1	SENSOR, FACE SEAL (FKM)	43-0000-41	43-0000-41	NO	NO
N/A	N/A	SEAL KIT (STANDARD)	60-1400-26	60-1400-20	INCLUDED IN KIT	
N	N	SEAL KIT (FKM)	6V-1400-26	6V-1400-20	INCLUDED IN KIT	

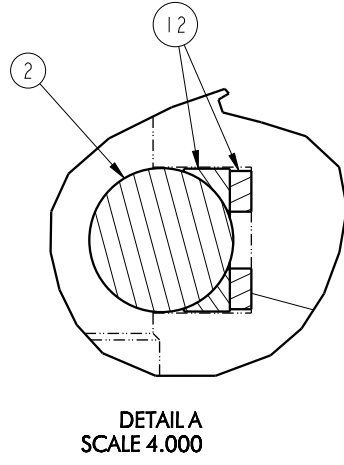
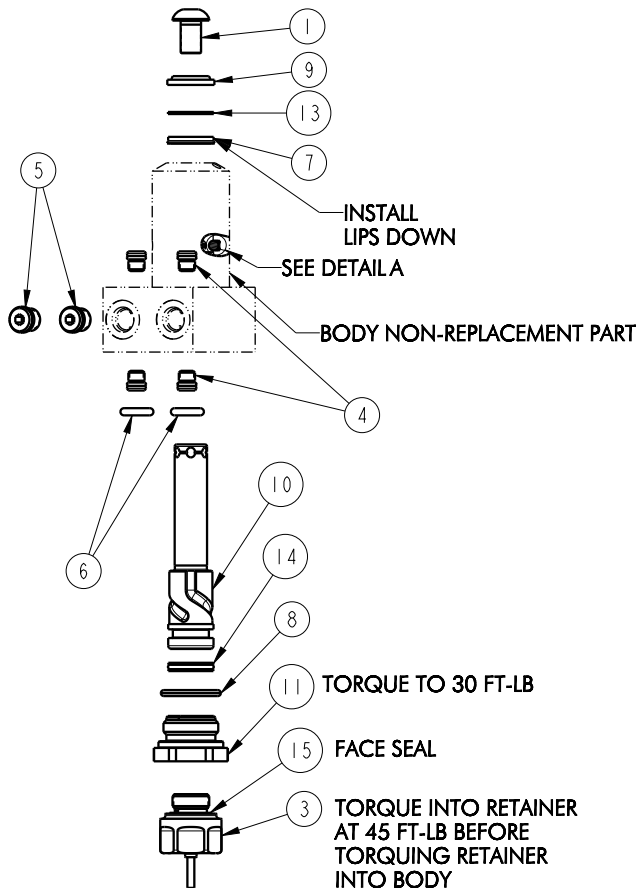

Lubricate all seals with clean hydraulic fluid prior to assembly.

PARTS LIST	
	VEKTEK, INC. 1334 E. SIXTH AVE. P.O. BOX 625 EMPORIA, KS. 66801 U.S.A.
ASSEMBLIES AFFECTED 14-2209-01-X-US 14-2213-01-X-US	PARTS LIST, ASSY, SC, HS, BF, DA, US
SIZE A	PL1454
	REV A

A	5531	RELEASE	ALS	11/5/24
REV	IN ACCORDANCE WITH ECN	EFFECTIVE DATE	REVISED BY	DATE
DRW BY:	ALS	DRAWING STATUS: Released PRODUCTION APPROVED FOR RELEASED STATUS ONLY		
DATE:	7/8/24			

SHEET 1 OF 1